



**LIFTON**

Home Lift

**LiftonDUO**

Technical  
Specification



# Floor Plan

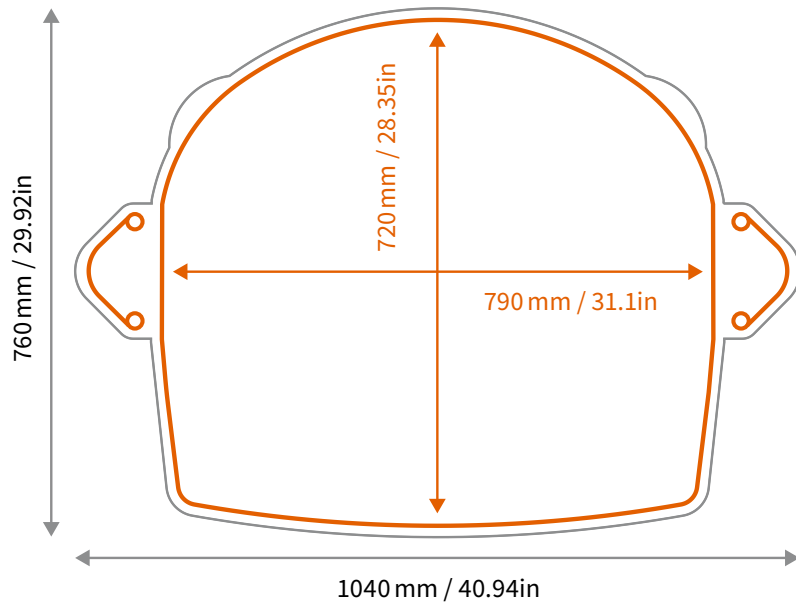

A design which is sturdy, intelligent and attractive. It is compact with a total footprint of only 1040mm x 760mm; including the rails.

# Technical Specification

<b>LIFT TYPE</b>	Domestic Personal Home Lift that complies with the Machinery Directive 2006 / 42 / EC
<b>HEIGHT LIMIT</b>	Single floor. With a maximum of 4000mm of travel
<b>ELECTRICITY</b>	230V socket – Plugs into a normal 13 amp power socket
<b>LOAD CAPACITY</b>	Max. 170kg / 2 people
<b>DRIVE</b>	Self-contained wire rope hoist system located in lift car roof space
<b>SPEED</b>	Up to 150mm / sec
<b>DIMENSIONS</b>	1940mm Internal lift car height 790 x 720mm Lift car footprint 1040 x 760mm Overall footprint
<b>LIFT CAR DOOR</b>	1100mm hinged half-height door or full-height door options available. Full height LED light curtain will protect entire door height
<b>ILLUMINATION</b>	Contemporary ambient lighting with high-quality LED strips
<b>CONTROL</b>	Lift is controlled via the control panel and two remote controls. Additional remote controls are available
<b>LIFT HEIGHT</b>	A minimum upper floor ceiling height of 2250mm is required

# Installation Options

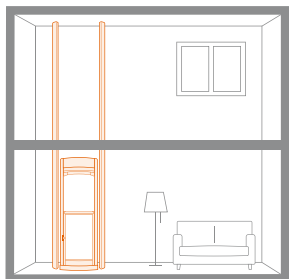

Living room

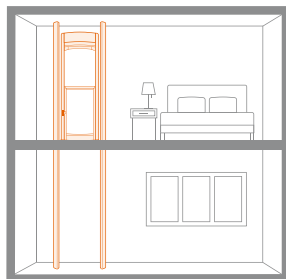

Upstairs bedroom



Stairwell void/landing

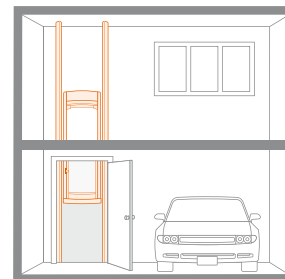

Garage

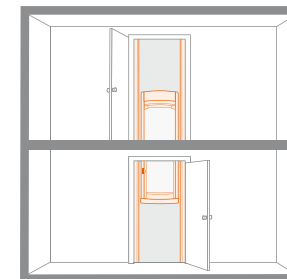

Cupboard installation

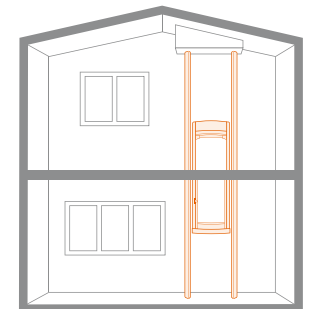

Sloping or vaulted ceilings

# LiftonDUO Concept

## 1. Flexible

Due to the vertical, self supporting stilts, positioning a Lifton Home Lift into your home is very flexible. It is free standing so no load-bearing walls are required, and you don't need to worry about window or radiators being in the way. It can tuck into the corner of a room, the stairwell void, on a landing or even in a cupboard!

## 2. Space Saving

No visible hoists and no noisy motors. Lifton Home Lifts' unique technology means the lift runs using discreet wire rope hoists and built-in drive equipment which is all neatly concealed within the lift car roof space. Meaning more space in your home for you, your furniture and your décor.

## 3. Simple

Lifton Home Lifts plug directly into your domestic power sockets. In the event of a power cut, a battery back up will gently return you to the ground until power is restored. To get you from floor to floor, the lift is operated using the intuitive in-car control panel or through remote controls from outside the lift.

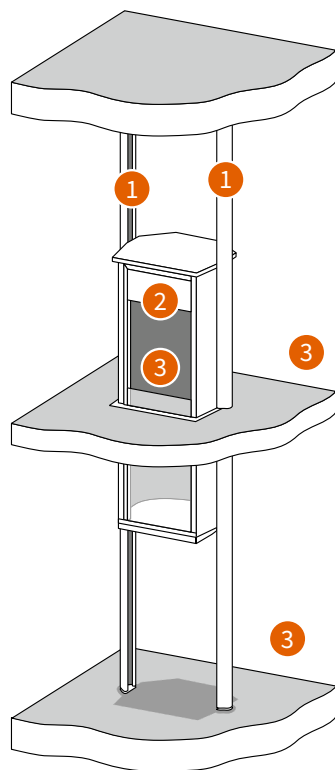

# Safety Features

To guarantee safe and comfortable usage at all times, each Lifton Home Lift is equipped with the following safety features as standard:

1. The half-height door is equipped with a subtle LED light curtain which detects obstacles and gently brings the lift to a stop if the light is crossed. This feature is available as an optional extra with the full height door.
2. The lift will only move from stationary when the lift car door is fully closed.
3. The lift has a built-in braking mechanism for safety and comfort.
4. Sensors positioned to the top and bottom of the lift will automatically stop the lift car immediately an obstruction is detected.
5. In the event of power failure, the lift car can be returned to the lower floor thanks to a battery back up located within the drive unit.
6. A built-in load sensor ensures that the maximum weight limit is not exceeded.
7. The lift car door is secured by a strong locking mechanism which is also very easy to open and close.



## Intelligent technology designed to enable Easy Living

For more information please  
get in touch with us on

**0808 274 4038**

Or visit **[www.lifton.co.uk](http://www.lifton.co.uk)**

### Nationwide locations of Lifton Home Lifts consultants

- Sheffield, South Yorkshire
- Maesteg, Mid Glamorgan, Wales
- Sutton Coldfield, West Midlands
- Amersham, Buckinghamshire
- Westcliff-on-Sea, Essex
- Wokingham, Berkshire
- Snodland, Kent
- Rhymney, Gwent, Wales
- Stourbridge, West Midlands
- Edinburgh, Scotland
- Exeter, Devon
- Peterborough, Cambridgeshire



 **Southern Office**  
Unit 13, Anglo Trade Park  
Fishponds Road  
Wokingham  
Berkshire  
RG41 2AN

 **Midlands Office**  
Building 5, Bay 1  
First Avenue  
Pensnett Estate  
Kingswinford  
DY6 7TE

 **Northern Office**  
4, The Courtyard Building  
Thorpe Lane  
Guiselley, Leeds  
West Yorkshire  
LS20 8LG

